



Retain this owner's manual for future reference.
Read and follow all instructions in this owner's manual.

INTRODUCTION



CAUTION!

BEFORE BEGINNING ANY EXERCISE PROGRAM, ALWAYS CONSULT YOUR PHYSICIAN. IF YOU EXPERIENCE CHEST PAINS, NAUSEA, DIZZINESS OR SHORTNESS OF BREATH, CONSULT YOUR PHYSICIAN BEFORE CONTINUING.

KEY FEATURES

CAUTION:

Before beginning any exercise program always consult your physician. If you experience chest pains, nausea, dizziness or shortness of breath, stop exercising and consult your physician before continuing.

Congratulations on choosing a HealthStream treadmill.

You have taken the first step to a healthier and more rewarding lifestyle.

T510 treadmill is especially designed to give you reliable performance and enjoyable workout in the comforts of your home. Please find below the features and benefits of this treadmill.

- ◇ Patented foldable treadmill so close to the ground, it is structurally more safe and stable so that you can feel at ease when you run or jog on the treadmill.
- ◇ When deck is folded more than 10 degrees off the ground, a safety Sensor will automatically shut off the main power.
- ◇ Gas assisted lift makes folding and unfolding of the deck safe and easy.
- ◇ The folding lock release mechanism is located at the end of the deck so that when folded, only adults can access the release.
- ◇ No need to tilt the treadmill when you want to move it to another location. When folded, hidden wheels will surface to engage the ground so that you simply roll the treadmill on four wheels to the desired location.
- ◇ Wireless pulse receiver compatible with Polar and CardioSport chest straps to monitor your heart rate during exercise.
- ◇ Low impact design with cushions so that your joints are protected against possible injury.
- ◇ Self-centering belt alignment so that the running belt is always tracked correctly in the center.
- ◇ Two large stop buttons for both right and left handed users.

CONTENT

I.	IMPORTANT SAFETY PRECAUTIONS	5
	Grounding Instructions.....	
	Electrical Safety.....	
	Mechanical Safety.....	
	Appropriate Attire.....	
	Children and Pets.....	
II.	ASSEMBLY INSTRUCTIONS	7
III	SETTING UP YOUR TREADMILL	8
	Placement in Your Home.....	
	Leveling the Base.....	
	Use Dedicated Circuit.....	
IV.	HANDLING YOUR TREADMILL	9
	Folding and Unfolding the Treadmill.....	
	Moving the Treadmill.....	
V.	GETTING STARTED	10
	Turn Power on.....	
	Safety Tether Key and Clip.....	
	Getting on and off the Treadmill.....	
VI.	OPERATING THE CONSOLE	12
	Display Values and Function Keys.....	
	Training without Preset Programs.....	
	Training with User Set Targets.....	
	Training with Preset Programs.....	
VII.	EXERCISE TIPS AND GUIDELINES	15
	Stretch.....	
	Warm Up.....	
	Cool Down.....	
	How Often.....	
	How Long.....	
	How Hard.....	
	Target Heart Rate.....	
VIII.	MAINTENANCE	17
	Cleaning.....	
	Running Belt Centering Adjustment.....	
	Running Belt Tension Adjustment.....	
	Lubricating the Deck.....	
IX.	TROUBLE SHOOTING	19
	When to Call for Help.....	
	No Signal on the Console LCD Windows.....	
	Error Codes.....	
	Trouble Shooting Guide.....	
X.	WARRANTY	22

I. IMPORTANT SAFETY PRECAUTIONS

When using an electrical product, basic precautions should always be followed. Read all instructions before using this treadmill.

WARNING!

Connect this unit to a properly grounded outlet only.

GROUNDING INSTRUCTIONS

This product must be grounded! If treadmill should malfunction or breakdown, grounding provides a path of least resistance for electrical current to reduce the risk of electrical shock. This product is equipped with a cord having an equipment-grounding conductor and a grounding plug. This plug must be plugged into an appropriate outlet that is properly installed and grounded in accordance with local codes and ordinances.

DANGER! Improper connection of the equipment-grounding conductor can result in a risk of electric shock. Check with a qualified electrician or serviceman if you are in doubt as to whether the product is properly grounded. Do not modify the plug provided with the product – if it will not fit the outlet, have a proper outlet installed by a qualified electrician.

ELECTRICAL SAFETY

To reduce the risk of burns, fire, electrical shock, or injury to persons, take the following precautions.

- When plugged in, do not leave the treadmill unattended at any time. Unplug the treadmill from the power source when it is not in use.
- Do not use the treadmill if the unit is wet or the plug or cable is damaged or the treadmill is not working properly. Do not use a damaged or defective equipment.
- Keep the power cable and plug away from heated surfaces.
- Never place the power cord under carpeting or place any object on top of the power cord.
- Use only the power cord provided with this treadmill.
- To disconnect, turn the switch to the off position, then remove the plug from the outlet.

This exercise equipment is designed and built for optimum safety for the home use. However, certain precautions always apply whenever you operate any exercise equipment. Be sure to read the entire manual before assembly and operation of this machine. Also, please note the following safety precautions.

CAUTION!

Stop your workout immediately if you feel any pain or abnormal symptoms and consult your physician.

Read this manual before operating this treadmill.

MECHANICAL SAFETY

- Before you start to exercise, make sure the unit functions correctly. To maintain the safety level of the exercise equipment does not use a faulty device.
- Replace defective components immediately and/or keep the equipment out of use until repair.
- Inspect the equipment prior to exercising to ensure that all nuts and bolts are fully tightened before each use.
- Do not use attachments not recommended by the manufacturer.
- Never drop or insert any object into any opening.
- Only one person may use the treadmill at a time.
- Never activate the speed when someone is standing on the treadmill.

APPROPRIATE ATTIRE

- Always wear appropriate clothing. Do not wear clothing that might catch on any part of this treadmill.
- Always wear non-slippery shoes while working with the treadmill. Do not wear shoes with heels or leather soles. Check the soles of your shoes and remove any dirt and embedded stones.

CHILDREN AND PETS

- Most exercise equipment is not recommended for small children. Children should not use the equipment unless they are under adult supervision. To ensure safety, keep young children off the treadmill at all times.
- Exercise equipment has many moving parts. In the interest of safety, keep others (especially children and pets) at a safe distance while you exercise.

II. ASSEMBLY INSTRUCTIONS

CAUTION:

To avoid injury, you must fold up the deck prior to lifting the treadmill out of the box

NOTE:

** Use star washer for each bolt connection.

*** Tare care that the cables do not get trapped or pinched.

Only one tool is required to assemble the treadmill.
This tool is provided along with the bolt pack.
Keep the tool to tension the running belt in the future.

1. ASSEMBLE THE UPRIGHT POSTS

Connect the wires before you assemble the upright posts.

Secure each upright post with four washers and four bolts.

Do not tighten these bolts until the horizontal handlebar and monitor have been tightened.

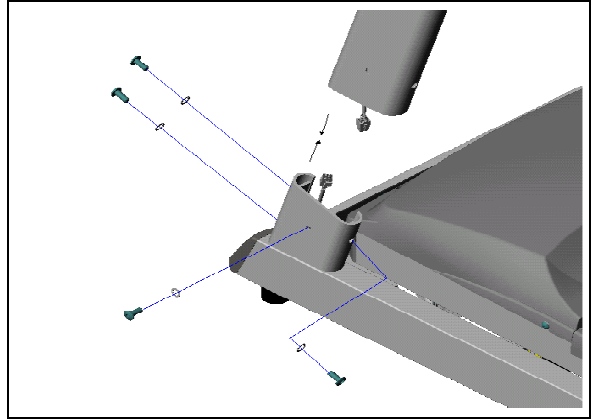

2. ASSEMBLE THE HORIZONTAL BAR

One end of the horizontal handlebar is not covered all the way with foam grip. Insert the uncovered end of the bar into right upright post first before fitting the other end flush against left side.

Do not tighten these bolts until the monitor has been tightened.

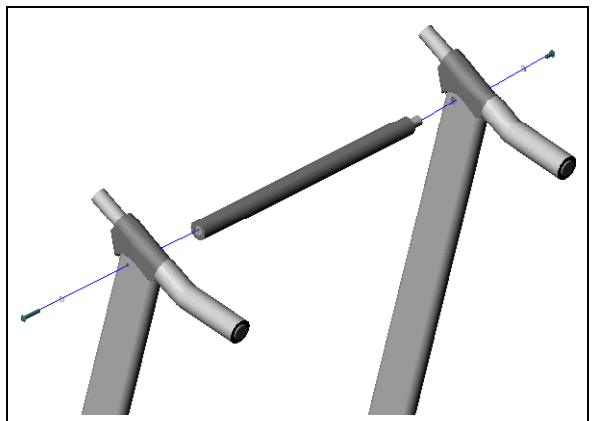

3. ASSEMBLE THE CONSOLE

Connect the wires. Then push the monitor onto the upright posts. You may have to shake the posts from side to side to get the console to fit.

Once you have the console in place, secure and tighten the bolts on the console.

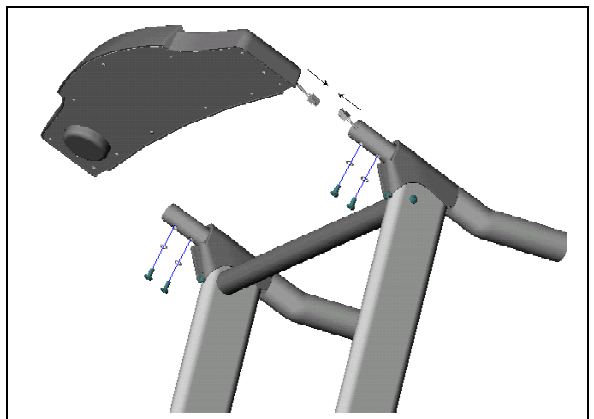

NOTE:

The left side of the horizontal bar is secured with the long bolt and the right side is secured with short

III. SETTING UP YOUR TREADMILL

CAUTION:

Make sure the running deck is level to the ground. If the deck is positioned on uneven surface, it would cause premature damage to the electronic system.

PLACEMENT IN YOUR HOME

To make exercise a desirable daily activity for you, the treadmill should be placed in a comfortable and attractive setting. This treadmill is designed to use minimal floor space and to go nicely in your home.

- Do not place the treadmill outdoors.
- Do not place the treadmill near water or in high moisture content environment.
- Make sure power cord is not in the path of heavy traffic.
- If your room is carpeted, check the clearance to make sure there is enough space between the carpet fiber and the treadmill deck. If you are uncertain, it is best to place a mat beneath your treadmill.
- Locate the treadmill at least 4 feet from walls or furniture.
- Allow the safety area of 20m X 10m behind the treadmill so that you can easily get on and off the treadmill without getting trapped during an emergency.

Occasionally after extended use you will find a fine black dust below your treadmill. This is normal wear and DOES NOT mean there is anything wrong with your treadmill. This dust can be easily removed with a vacuum cleaner. If you wish to prevent this dust from getting on your floor or carpet, place a mat beneath your treadmill.

LEVELING THE BASE

It is important that you place the treadmill on a firm level surface.

Check the treadmill to ensure the frame is level once you have moved the treadmill into the position of your choice.

USE DEDICATED CIRCUIT

The outlet selected should be a dedicated circuit. It is particularly important that No sensitive electrical equipment, such as computer or TV, share the same circuit.

IV. HANDLING YOUR TREADMILL

FOLDING THE TREADMILL

Folding and unfolding of this treadmill is made easy with the assistance of gas shock. After the treadmill has come to a complete stop, make sure the elevation is lowered all the way to the ground before folding the treadmill. With caution, fold up the deck slowly with both hands. When you hear a click, the deck is locked in place.

UNFOLDING THE TREADMILL

The release handle is located on the end of left Main Frame, which is very near to the left End-cap. To unfold the treadmill, use your left hand to reach up to the end of left Main Frame, gently turn the release handle clockwise. Use your right hand to unfold the deck slowly. Use both hands to bring the deck slowly to the ground. Please handle with caution. As the deck gets closer to the ground, it will drop at a faster rate and feel heavier.

MOVING THE TREADMILL

This treadmill is easy to move around safely.

To move the treadmill:

1. Turn power switch off.
2. Unplug the power cord.
3. Make sure the deck is at 0% grade.
4. Fold the treadmill and make sure lock is engaged. You should hear a click to indicate positive engagement.
5. Simply roll the treadmill on four wheels to the desired location.

STORING THE TREADMILL

For safety precaution, especially when you have children in the house, we recommend that you follow these steps to keep the treadmill out of harm's way.

1. Turn off the power switch when you have finished workout.
2. Discount the plug from the wall socket.
3. Remove the safety tether key and store out of reach of children.

V. GETTING STARTED

TURN POWER ON

WARNING!

Never use this treadmill without first securing the safety tether clip to your clothing.

CAUTION!

For your safety, step onto the belt when the speed is no more than 2 Km/H.

Never start the treadmill at a running speed and attempt to get on while it is moving fast.

NOTE!

The deck should NOT be folded unless the elevation is at 0% grade. Attempts to fold the deck while it is elevated may cause damage to the frame.

The On/Off switch for the treadmill is located next to the power supply cord at the back of the motor cover. Flip this switch to the "ON" position.

SAFETY TETHER KEY AND CLIP

The safety key is designed to cut the main power to the treadmill should you fall. Therefore, the safety key is designed to bring the treadmill to an immediate stop. At high speeds, it may be uncomfortable and somewhat dangerous to come to a complete stop immediately. So, use the safety key as emergency stop only. To bring the treadmill to a complete stop safely and comfortably, use the red stop button.

Your treadmill will not start unless the safety key is properly inserted into the key holder at the left side of the console. The other end of the safety key should be securely clipped to your clothing so that in the case that you fall, you will pull the safety key from the console, which will stop the treadmill immediately to minimize injury. For your safety, never use the treadmill without securing the safety key clipped to your clothing. Pull on the safety key clip to make sure it will not come off your clothing.

GETTING ON AND OFF THE TREADMILL

Handle with care when getting on or off the treadmill. Try to use the handlebars while getting on or off. While you are preparing to use the treadmill, do not stand on the running belt. Straddle the running belt by placing your feet on both side rails of the treadmill deck. Place your foot on the belt only after the belt has begun to move at a consistent slow speed.

During exercise, keep your body and head facing forward at all times. Never attempt to turn around on the treadmill when the running belt is still moving. When you have finished exercising, stop the treadmill by pressing the red stop button. Wait until the treadmill comes to a complete stop before attempting to get off the treadmill.

VI. OPERATING THE CONSOLE

DISPLAY VALUES

Elevation	0 – 10% grade	1% increment
Time	0:00 to 59:59	One second increment
Calories	0 – 999 calories	One calories increment
Pulse	40 – 240	One pulse beat increment
Distance	0 – 99.9 Km	0.1 Km increment
Speed	1 – 16 Km/H	0.1 Km/H increment

FUNCTION KEYS

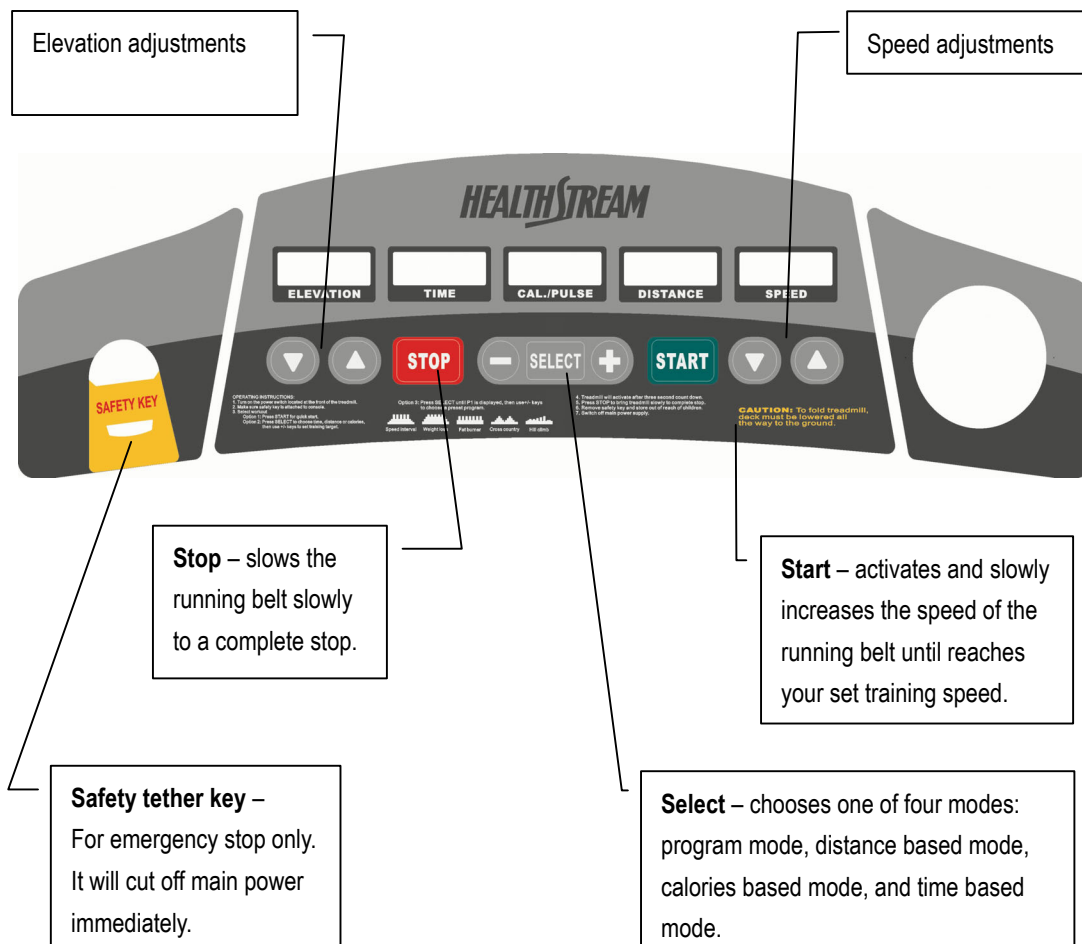

QUICK START

Once the power is on and the safety tether key is secured in place, simply press the green start button, and a three second count down will activate and maintain the running mat at 1Km/H.

TRAINING WITHOUT PRESET PROGRAMS

Once the power is turned on and the safety key is secured in place, you will see all values display zero. Select one of the following methods to workout with your treadmill.

QUICK START

Manually controlled workout. No time limitation. Speed preset at 1Km/H at 0% elevation. During workout, user may adjust speed and or elevation. Simply press **START**, after a three second count down, treadmill will pick up speed.

MANUAL MODE

Manually controlled workout. No time limitation. User set speed and or elevation. During workout, user may adjust speed and or elevation, then press **START**. After a three second count down, treadmill will pick up speed.

TRAINING WITH USER SET TARGETS

Users have the option to set training target to achieve their fitness goals. Users may set targets with distance, calories or time. This type of workout has speed preset at 1Km/H and elevation at 0% grade. During workout user may adjust speed and or elevation.

Target Distance

User set workout with target distance.
Maximum target distance: 99.9 Km.

Target Calories

User set workout with target calories.
Maximum target: 999 calories.

Target Time

User set workout with target length of time.
Maximum target: 60 minutes.

TO WORKOUT WITH TARGET SETTING MODES:

1. Turn on the power
2. Secure the safety key in place
3. Press **SELECT** to choose time or distance or calories mode
4. Use **+ -** key to set the target value
5. Press **START** to activate treadmill
6. After a three second count down, treadmill will pick up speed

NOTE:

This model is not designed for therapeutic purposes. Pulse rate and calories consumption values displayed on the monitor are motivational values only.

TRAINING WITH PERSET PROGRAMS

There are five pre-set programs. Each program is 30 minutes long, divided into 15 segments each 2 minutes long.

User may select intensity level of the workout by selecting the top speed in speed-based programs or the top elevation in the elevation-based programs.

Speed programs – workout will vary by speed according to preset profile. During data entry, user may adjust top speed, which is preset at 10 Km/H. During workout, user may adjust elevation, but not speed.

- P1 – Speed interval
- P2 – Weight loss

Elevation programs – workout will vary by elevation according to preset profile. During data entry, user may adjust top elevation, which is preset at 8% grade. During workout, user may adjust speed, but not elevation.

- P3 – Fat burner
- P4 – Cross country
- P5 – Hill climb

TO WORKOUT WITH PRE-SET PROGRAMS:

1. Turn on the power
2. Secure the safety key in place
3. Press **SELECT** until P1 shows
4. Use + - keys to choose the desired program: P1 – P5
5. Use \triangle ∇ to adjust the intensity level (top speed or maximum elevation) if the preset is not appropriate
6. Press **START** to activate treadmill
7. After a three second count down, treadmill picks up speed

VII. EXERCISE TIPS AND GUIDELINES

CAUTION!

Always consult your physician before beginning any exercise program.

STRETCH

Stretching prior to exercise will improve flexibility and reduce chances of exercise related injury. Ease into each of these stretches with a slow gentle motion. Hold for a count of ten. Do not bounce. Repeat the stretch exercises again after the cool down will help to loosen and relax your muscles to prevent soreness.

WARM UP

The first five minutes of a work out should be devoted to warming up. This warm up will limber your muscles and prepare them for more strenuous exercise. Warm up on the treadmill by walking at slow speeds.

COOL DOWN

Never stop exercising suddenly. A cool down period of about 5 minutes will allow your heart to readjust to the decreased demand. Use a low speed setting during the cool down to gradually lower your heart rate.

HOW OFTEN?

It is most often recommended that you exercise at least three to four times a week to maintain cardiovascular fitness. If you have other goals such as weight or fat loss, you will achieve your goal faster with more frequent exercise. Whether it is three days or six days, remember that your ultimate goal should be to make exercise a lifetime habit.

HOW LONG?

For aerobic exercise benefits, it is recommended that you exercise for about thirty minutes per session. Always start slowly, especially if you have been sedentary during the past year. In the beginning you may begin with as little as five minutes per session. Your body will need time to adjust to the new activity. As your body adjusts, gradually increase your workout time per session.

If your goal is weight loss, a longer exercise session at lower intensities has been found to be most effective. A workout time of 45-50 minutes or more is recommended for best weight loss results.

CAUTION!

For your health and safety, Do not over exert yourself.

CAUTION!

If you experience chest pains, nausea, dizziness or shortness of breath, stop exercising immediately and consult your physician before continuing.

HOW HARD?

How hard you work out is determined by your goal. Regardless of your fitness goals, always begin an exercise program at low intensity. Aerobic exercise does not have to be painful to be beneficial!

There are two ways to measure your exercise intensity. The first is by evaluating your perceived exertion level and the second is by monitoring your heart rate.

During exercise, if you cannot maintain a conversation without gasping, you are working too hard. A good rule of thumb is to work to the point of exhilaration, not exhaustion. If you cannot catch your breath, it is time to slow down. Always be aware of other warning signs to overexertion.

To monitor your heart rate you can use a pulse monitor or take your pulse with your fingers. Pulse monitors are convenient tools for monitoring your heart rate. However, these values are for reference only. You should always listen to your body first.

You can measure your pulse with your fingers by placing your first two fingers lightly over the blood vessel (carotid artery) on your neck located next to your Adam’s apple. Count your pulse for ten seconds and multiply by six. This figure is your heart rate in beats per minute. Compare this number to the Target Heart rate zone for your age group.

TARGET HEART RATE

Age	Target Zone (60% - 75%)
20	120 – 150
25	117 - 146
30	114 - 142
35	111 - 138
40	108 - 135
45	105 - 131
50	102 - 127
55	99 - 123
60	96 - 120
65	93 - 116
70	90 - 113

TARGET HEART RATE

The most common method for calculating your target heart rate is to find your maximum heart rate. The standard formula for this is: 220 - your age = maximum heart rate.

You DO NOT want to workout at your maximum heart rate. You want to workout in your target heart rate zone. Your target heart rate zone is a percentage of your maximum heart rate. The American Heart Association recommends working out at a target heart rate zone of between 60% - 75% of your maximum heart rate. If you are just beginning an exercise program, exercise near or below the lower limit of your target zone.

Lower limit of target zone = maximum heart rate x 0.60

Upper limit of target zone = maximum heart rate x 0.75

VIII. MAINTENANCE

DANGER!

To reduce the risk of electrical shock, always unplug the treadmill from the electrical outlet immediately after use and before cleaning.

CLEANING

Remove dust on the treadmill with vacuum or slightly damp cloth. Fold up the deck and clean the floor with vacuum periodically will help to prolong the treadmill product life.

Never use solvents on the deck or running belt. Use of solvents can reduce critical lubrication of the deck and belt.

RUNNING BELT CENTERING ADJUSTMENT

When you run or walk, you may push off harder with one foot than the other. This will cause the running belt to run off centered. This treadmill is designed and built to ensure proper tracking of the belt is always centered on the deck. Occasionally the belt may need further adjustment to keep it centered. To center the belt, use the enclosed Allen wrench to adjust the rear roller position.

BELT CENTERING PROCEDURE

1. Do not wear loose clothing, neckties, or loose jewelry while making this adjustment.
2. Never turn the bolts more than 1/4 turn at a time.
3. Always tighten one side and loosen the other to prevent over tightening or loosening the belt.
4. Run the treadmill. Adjust belt while the treadmill is running at 4 Mi/H (6.4 Km/H) with no person on the belt.

After making the adjustment walk on the belt for five minutes to test. If necessary, repeat the procedure but never turn the bolts more than 1/4 turn at a time. Over tightening the belt can significantly shorten the belt life.

IF BELT TOO FAR TO THE LEFT SIDE:

1. Turn the left roller bolt 1/4 turn clockwise (tighten)
2. Turn the right roller bolt 1/4 turn counterclockwise (loosen)

IF BELT TOO FAR TO THE RIGHT SIDE:

1. Turn the right roller bolt 1/4 turn clockwise (tighten)
2. Turn the left roller bolt 1/4 turn counterclockwise (loosen)

RUNNING BELT TENSIONING ADJUSTMENT

CAUTION!

Over tightening of the belt will severely shorten the life of the belt and may cause further damage to other

If when you plant your foot on the belt, you can feel a slipping sensation then the belt has stretched and is slipping across the rollers. All belts will stretch over time. This is a normal and common adjustment on any treadmill. To eliminate this slipping, tension both Allen bolts on the rear roller 1/4 turn as shown. Try the treadmill again to check for slipping. Repeat if necessary, but never turn the roller bolts more than 1/4 turn at a time.

DRIVE BELT TENSIONING ADJUSTMENT

If you have tensioned the running belt and are still experiencing a slipping sensation, call your dealer. Only an authorized dealer should perform tensioning of the drive belt.

LUBRICATING THE DECK

A well-lubricated deck will ensure high performance of your treadmill and reduce the level of normal wear and tear to important components. This treadmill has been pre-lubed at the factory. However, for optimal performance, the running deck may require periodic lubrication. With average usage (30 minute workout session at 5-6 Km/H 3 times a week for two people) lubricate every four to six months. You may adjust the timing of the lubrication based on the intensity of the treadmill use level.

To check the lubrication level, simply lift the running belt, and put your hand as far into the center of the belt as you can reach. If your hand shows signs of silicone, then it does not need additional lubrication. If the board feels dry and there is very little evidence of silicone on your hand, then additional lubrication should be added.

TO LUBRICATE THE DECK:

1. Stop running belt so that the seam is located on top and in the center of the deck.
2. Insert nozzle into spray head of lubricant can.
3. Lift running belt.
4. Position nozzle between the belt and the board approximately 200mm (8") from the front of the treadmill.
5. Apply the silicon from the front to the rear of the treadmill on each side of the treadmill. Try to reach the spray as far into the center of the running deck as possible. The spray time should be approximately four seconds for each side.
6. Spread the silicon by running the treadmill at 1 Km/H and step gently on the belt from left to right. Do that for a few minutes and allow the silicon to soak into the belt.

IX. TROUBLE SHOOTING

WHEN TO CALL FOR HELP

This treadmill is designed with user safety as the number one priority. In the event of electrical failure, the treadmill will shut off automatically to prevent user injury and to prevent damage to expensive components such as the motor.

When you encounter unusual behavior from the treadmill, simply go to the front of the treadmill, turn the power switch off and on to reset the treadmill. This should clear incidental errors and ready the treadmill for normal operation again.

If after you have reset the treadmill by turning the power switch off and on again, and the treadmill is still not operational, then it is time to call your dealer for service.

NO SIGNAL ON THE CONSOLE LCD WINDOWS

If there is no signal on the console, even if you turn off and turn on many times to reset the treadmill, check the communication cable between console and motor controller.

First, make sure the connections are good and that the cable is not pinched or damaged. If defective, ask your dealer for a replacement cable.

ERROR CODES

ERROR 1 – SPEED SENSOR ERROR

Error 1 occurs when console is not picking up the motor speed signal. In other words, when motor speed is not correctly feed back to the controller and console, treadmill will shut off to protect user and error 1 will be displayed on the console. When trouble shooting this error, do not stand on the running belt.

When you report error 1 to the service center, make sure you note down the circumstantial details.

1. Is the motor operational? For example, motor is not working when you push the start button, error 1 displays immediately. Motor and running belt do not move.
2. If treadmill was running, then it stopped and showed error 1, then motor is operational.
3. If motor is operational, did the treadmill stop at low speeds (1.0 – 1.5 Km/H) or high speeds (10 KPH – 12 KPH)

ERROR 2 – OVER SPEED ERROR

Error 2 occurs when actual belt speed is faster than displayed speed on the console. This is also called run away protection. If controller is broken, and the motor is running out of control, it is dangerous to the user. So, this is a safety mechanism to shut off the treadmill immediately when the actual speed is faster than the displayed speed. When troubleshooting this error, do not stand on the running belt.

If you see error 2 when you first turn on the power to the treadmill, before the motor had moved. One possibility for the error 2 occurring is because the belt had moved before motor actually move. This could happen during handling of treadmill. The controller thinks motor moved even though it has not given power to the motor. So, controller thinks something is wrong. Simply turn power off and on again to reset.

If user is pushing hard on the running belt to cause the belt to run faster than the displayed speed, error 2 will also occur. Simply turn power off and on again to reset.

While the treadmill is running, it suddenly speed up quickly and stopped and displayed error 2 on the console. This means controller is damaged and motor is running out of control. Call your dealer for service. Do not use the treadmill until it is repaired.

ERROR 3 – SAFETY TETHER KEY ERROR

Error 3 occurs when safety tether key is not in positive contact with the console. Check for positive contact of the safety key to the console.

ERROR 5 – INCLINE MOTOR ERROR

This error occurs when the incline motor is not functioning properly.

1. Incline motor is over-loaded or over-heated. Simply wait until the incline motor has returned to normal temperature, then try again.
2. Sensor connection cable has problem
3. Sensor (Potentiometer) is defective or damaged
4. Incline motor is damaged

ERROR 11 – COMMUNICATION ERROR

This error occurs when the communication between console and controller is not functioning properly. Check the communication line connections first to make sure it is not loose or the cables are not pinched. If communication cable is damaged, change it. Turn power off and on to reset the treadmill.

TROUBLE SHOOTING GUIDE

Problem	Potential Cause	Corrections
Treadmill will not start	<ol style="list-style-type: none"> 1. Not plugged in 2. Safety tether not inserted 3. House circuit breaker tripped 4. Treadmill circuit breaker tripped 5. On/Off switch on OFF 	<ol style="list-style-type: none"> 1. Plug into grounded outlet. 2. Insert safety tether into console. 3. Reset or replace fuse. 4. Lubricate treadmill deck and reset. 5. Turn on/Off switch to ON
Running belt slips	<ol style="list-style-type: none"> 1. Running belt not tight enough 2. Drive belt not tight enough 	<ol style="list-style-type: none"> 1. Adjust running belt tension 2. Adjust drive belt tension
Running belt hesitates when stepped on	<ol style="list-style-type: none"> 1. Insufficient lubrication 2. Running belt too tight 	<ol style="list-style-type: none"> 1. Apply silicone lubricant 2. Adjust running belt tension
Running belt is off centered	Running belt tension not even across the rear roller	Center the running belt

X. WARRANTY

TERMS AND CONDITIONS

This warranty is valid only in accordance with the conditions set forth below. Warranty applies only while the followings three conditions are met.

- It remains in the possession of the original purchaser and proof of purchase is demonstrated.
- It has not been subject to accident, misuse, abuse, improper service or unauthorized modifications.
- Claims are made within the 12 months manufacturer's warranty period.

EXCLUSIONS AND LIMITATIONS

This warranty is for home use only. Under no circumstances is this treadmill warranted for semi-commercial or commercial use.

Healthstream warrants this product to be free from defects in material and workmanship. This warranty is expressly limited to the replacement of a defective motor, electronic component, or defective part and is the sole remedy of the warranty. Labor for repair or replacement of defective parts is not covered by this warranty. The warranty does not cover normal wear and tear, improper assembly or maintenance or installation of parts or accessories not originally intended or compatible with the treadmill sold. The warranty does not apply to damage or failure due to accident, abuse, corrosion or neglect.

Manufacturer shall not be responsible for incidental or consequential damages.

WARRANTY REGISTRATION

The warranty registration must be completed in full. Send or fax this information along with a proof of purchase to your dealer to keep on file. Your dealer must have this information on file before a warranty claim can be processed.

WARRANTY REGISTRATION – Keep a copy for your records

Model #: _____

Serial #: _____

Date of purchase: _____

Your name: _____

Dealer name: _____

Address: _____

Dealer address: _____